

Farnelli

COMPANY SPECIALIZING IN BUILT-IN OVENS
AND HOBS

HOBS

PIA 60
INDUZIONE

INDUCTION
HOB



Installation and Operating Manual

Dear Customer!

Thank you for purchasing FORNELLI appliance. We hope that this product will meet your expectations and become an excellent assistant in your kitchen. To ensure proper and safe operation of the product, please, carefully read all the provisions of this Manual. Furthermore, please, keep this Manual for the entire service life of the unit.

First part of the Manual contains certain important preconditions for safe operation of the appliance. To ensure that your product will remain in perfect condition for a long time, we provided lots of useful and valuable tips concerning the appliance's care and cleaning. Additionally, this Manual provides some tips and tricks on energy saving.

In the event that some faults will encounter during the operation of the device, the last pages of the Manual contain useful troubleshooting advises.

Your appliance is made of high quality materials and fully conforms with all EEC standards. The household appliances that we offer are being constantly improved. This includes better functionality and features, updated appearance, so the pictures and designations used in the Manual may slightly differ from the model you have purchased.

Bon appetite!

The manufacturer reserves the right to make changes to the design of the appliance in order to improve its performance.

This product conforms with European standards and has valid CE, TUV, ISO 9001 and EAC conformity certificates.

Date of manufacture of your appliance is encoded in its serial number.

You will find the serial number of your product on the label, attached to exhaust. Here is the explanation of designations used in the serial number.

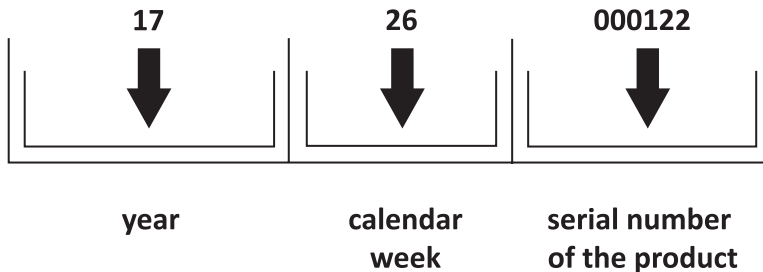

In this example the product was manufactured during 26th week of 2017.

Content

Induction Principle2

SAFETY INSTRUCTIONS AND ADVISES

Before you switch the new hob for the first time6

Safety requirements6

How to prevent damage of the hob8

Recommendations on disposal8

Scope of delivery9

Product certification details9

Storage9

Transportation9

Technical specifications10

YOUR NEW INDUCTION HOB

Control panel11

Hb peration12

Power/Temperature adjustment12

Timer12

Child lock12

Small item recognition12

Automatic cookware recognition13

Voltage surge protection13

Faulty temperature sensor protection13

Overheating protection13

Overvoltage protection13

Automatic switch-off13

Suitable cookware14

MAINTENANCE AND CLEANING..... 14

Slight contaminations15

Severe contaminations.....15

INSTALLING THE GLASS-CERAMIC HOB..... 16

Fastenning to the countertop16

Connection to electric mains18

Maintenance and repairs19

Troubleshooting20

Installation and Operating Manual

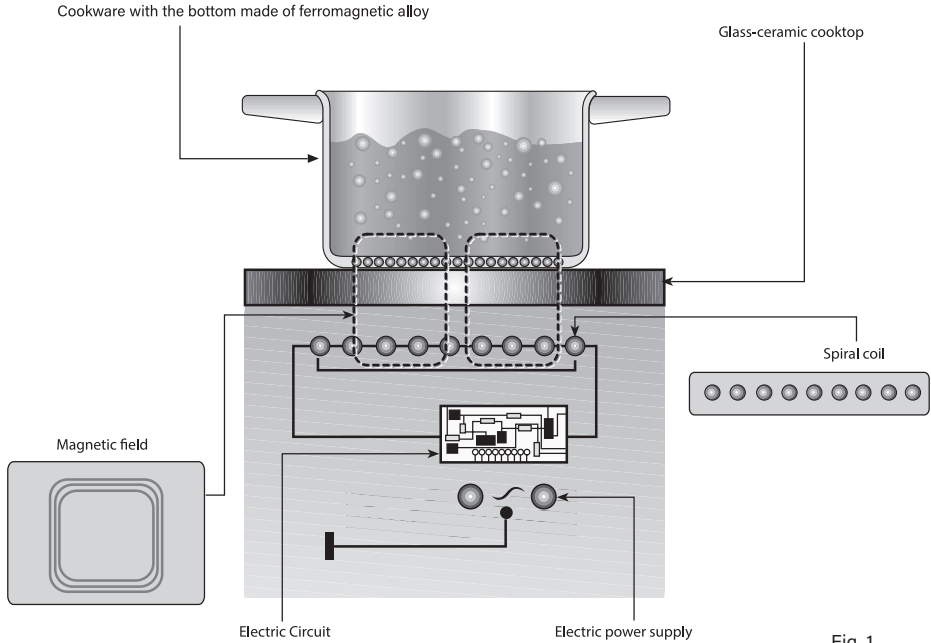

Fig. 1

INDUCTION PRINCIPLE

The induction cooking technology is based on the physical principle of magnetic induction.

Key feature of this technology is a direct transfer of energy from its generator to a cookware (unlike in the case of conventional burners – see Figure 1).

Advantages

As compared to electric hobs, your hob is:

- **Safer:** the glass surface heats up less.
- **Faster:** less time for heating the foods.
- **More accurate:** the hob instantly responds to your commands.
- **More effective:** 90% of consumed energy is converted into heat.

Moreover, immediately after removing the cookware from the hob surface the heat transfer stops, thus avoiding unnecessary dissipation of heat.

The system automatically recognizes the other diameter of each individual cookware and applies the power appropriate to the particular size of the cookware.

This allows the use of cookware of different sizes, provided that the diameter of a specific item corresponds to maximum 10% and minimum 40% of the size of the serigraphy on the surface of cooking hob (Figure 4)

WARNING: when using cookware with a diameter less than 40% of the size of the serigraphy on the hob surface, the cooking zone may not turn on.

Suitable cookware

Induction cooking is based on the use of magnetism to generate heat. Therefore, the cookware must be made of materials containing iron. You can check the material of your cookware with a simple magnet.

Important:

To avoid irreparable damage to the surface of the hob, do not use:

- cookware with uneven bottom
- metal cookware with enameled bottom
- cookware with rough, abrasive bottom to avoid scratching the surface of the hob.

SAFETY INSTRUCTIONS AND ADVISES

WARNING! To avoid damage of the glass-ceramic hob in the cold season, please, keep the unpacked hob at room temperature for at least 2 hours before the first switching-on.

BEFORE YOU SWITCH THE NEW HOB FOR THE FIRST TIME

After the hob packing is removed, make sure, that both the hob and the power cord are in good and proper condition and have no damages, Otherwise do not try to connect the hob to mains and contact your seller.

Please, keep in mind, that any modifications and/or attempts to make any modifications to the design of the product are risky. Do not disassemble and make any modifications to the hob. If necessary, contact technical service.

The hob must be installed and connected to mains by qualified and certified electrician from the service center in strict compliance with the installation manual and applicable safety regulations and standards.

SAFETY REQUIREMENTS

User of the glass-ceramic hob must know and comply with the safety rules on handling consumer electric appliances.

The hob must be connected to reliable and proper grounding system in conformity with applicable electrical safety regulations. In the event of any interventions into the hob's design the electric supply must be **OFF**. Manu-

facturer disclaims any and all liability whatsoever for any and all damages, which may be caused to people and property as a result of inappropriate grounding of the appliance.

The appliance must not be used by children and/or incapable people.

Never allow children to play with the hob. Before starting operation with the hob, people with implanted cardiac pacemakers shall make sure, that the hob does not cause interference with the cardiac pacemaker.

IMPORTANT!

- Never put on the hob any metal items, including spoons, knives, caps, etc., since they may get hot;
- after completion of the use, please, switch off the hob using a special command: do not rely on the cookware detector;
- avoid spilling of liquids. Never leave liquids on the hob unattended, or at least reduce power for their warming up and boiling;
- never leave operating induction burners of the hob with empty cookware or without cookware installed on top.
- Upon completion of cooking, turn off the corresponding induction burner with the command described below;
- Never use for cooking any aluminum foil sheets, never put on the hob any foods wrapped in foil. Aluminum can melt and irreparably damage your hob;
- Never warm up closed tin cans with foods: tin cans may explode! This rule applies to all other types of hobs.

When using electrical outlets located close to the hob, make sure that the power cords of the household appliances that you may use do not touch hot parts of the ceramic glass hob; make sure, that the power cords are laid suf-

Installation and Operating Manual

ficiently away from the hot part of the hob. The power cords must be attached to the kitchen countertops so that they do not come in contact with hot parts of the glass ceramic hob. Periodically (at least once every six months), check the condition of the electrical power cord. If any defects are found, such as cracks, melted insulation, hardening of insulation, please, immediately contact the service center. To avoid danger, the power cord must be replaced by a service center or similar qualified personnel.

In the event of overheating, fats and oils easily flammable. Therefore, it is absolutely required to cook food using an oil, for example, when cooking French fries, under continuous control only.

ALWAYS REMEMBER! Never use water to extinguish burning oil or fat. Cookware with easily flammable oil or fat should be tightly covered with a lid or a dense material to prevent access of oxygen to the flame.

Always keep the hob clean. Remains of food can cause fire.

Chips and cracks on the ceramic glass hob may result in electric shock. In case of finding thereof, immediately turn off the hob and disconnect it from electrical mains.

In the event of a breakdown, immediately disconnect the ceramic hob from electric mains.

Never operate faulty equipment, this is dangerous!

Do not attempt to repair the glass ceramic hob by yourself. Repairs performed by unqualified persons can result in equipment

damage and accidents. First of all, refer to these instructions. If it contains no information that you need, please, contact the nearest service center. This appliance must be repaired by authorized service center only. Always demand the use of original spare parts for repairs.

Installation and Operating Manual

HOW TO PREVENT DAMAGE OF THE HOB

Glass ceramics is resistant to drastic temperature changes, being a very strong material in relation to such temperature variations. However, in the course of operation glass ceramic hob is subjected to other impacts, for example, mechanical, in respect of which its strength is much lesser.

Never use the ceramic hob as a stand for various items or as a work table.

Never use cast iron cookware or cookware with a damaged bottom, having rough, abrasive bottom surface or burrs. Moving such cookware on the hob may result in scratching on the hob surface.

Never place empty cookware, especially enamel and aluminum ones, on the induction burner when it is ON. This can damage the hob and the bottom of the cookware.

Never store hard and sharp items over the ceramic hob. If they fall on the hob, the hob will most likely be damaged.

If sugar or other sugar-containing food fall onto the hot induction burner and get melted, immediately remove them with a cleaning scraper while they are still hot. When the hot mass cools down, it can damage the surface when being removed.

When getting in contact with hot induction burners, synthetic materials, aluminum or culinary foil or plastic utensils can get melted. Therefore, store these materials and items at safe distance from the glass ceramic hob. If, despite your efforts, some material has melted on the hob surface, immediately remove it with a scraper.

Always make sure, that acidic liquids, such as vinegar, lemon or lime scale dissolution agents, do not fall on the glass ceramic hob surface, since these substances leave matte stains on the surface.

Never put pans or frying pans on the hob frame, this may cause scratches and other damage.

Recommendations on Disposal

All the materials, used in the glass ceramic hob, are ecologically friendly and recyclable. Please, observe environment protection rules and regulations, use proper separate waste collection practices.



Used or damaged appliances are not useless wastes. Different materials, used in your hob, can be used repeatedly.

For more details on the hob disposal methods, please, contact your dealer or local administrative authorities.

When you hand over your hob for disposal, please, remember, having fallen into children's hands it may cause a serious accident. Make sure, that the hob you are about to dispose is as safe, as it is technically possible. For example, cut off its electric power cord, make the hob disables in any other way.

Follow the instructions contained in this Manual.

SCOPE OF DELIVERY

Your glass ceramic hob is a built-in kitchen appliance. Nameplate containing the model of the hob is attached to the rear side of the built-in part of the hob.

The scope of delivery includes:

- Glass ceramic hob – 1 pc.;
- Adhesive sealing plate – 1 pc.;
- User's Manual.

STORAGE

Store the hob in a dry place, away from sources of heat and direct sunlight. When storing an oven, avoid rapid temperature changes. Storing of the oven with the transportation packing removed is prohibited.

TRANSPORTATION

Falls and/or any mechanical impacts on the packaging during transportation of the product must be excluded.

SELLING REGULATIONS

Manufacturer does not implement any special rules and conditions regarding the selling of the product; the product must be marketed and sold in accordance with the national and/or local legislation of the country of destination.

TECHNICAL SPECIFICATIONS

Dimensions of the Hob and the Opening for Building-in of the Hob

Dimensions of the Hob's Built-in Part, mm	Height	Width	Depth (length)
Dimensions of the Visible Part	7	590	528
Dimensions of the built-in part of the hob	78,8	550	487
Niche dimensions	35-45*	565	500

* When the countertop thickness is less than 35 mm, use the additional sealing tape (to be purchased separately).

Total power of the glass ceramic hob, W – 6400.

Hob power supply: 220-240 V AC 50/60 Hz.

Ingress Protection: 1.

Size and power of induction burners

Burner	Dimensions, mm	Power, W
Front left	165	1200
Rear left	200	2000
Rear right	200	2000
Front left	165	1200

YOUR NEW GLASS CERAMIC HOB

1. Power cord
2. Glass ceramic hob
3. Rear left burner
4. Front left burner
5. Rear right burner
6. Front right burner
7. Sensor control panel
8. LED indicator.

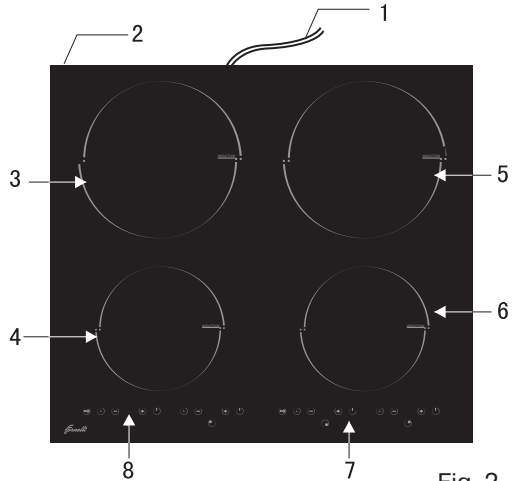

Fig. 2

Fig. 3

CONTROL PANEL



Front left burner functions:

1. Child Lock for left (rear and front) burners
2. Timer
3. Power/temperature adjustment ("-")
4. Display.
5. Power/temperature adjustment ("+")
6. ON/OFF

Rear left burner functions:

7. Timer
8. Power/temperature adjustment ("-")
9. Display
10. Power/temperature adjustment ("+")
11. ON/OFF .

Installation and Operating Manual

Front right burner functions:

12. Child Lock
13. Timer
14. Power/temperature adjustment ("-")
15. Display
16. Power/temperature adjustment ("+")
17. ON/OFF.

Rear right burner functions:

18. Timer
19. Power/temperature adjustment ("-")
20. Display
21. Power/temperature adjustment ("+")
22. ON/OFF.

HOB OPERATION

- a) Push ON/OFF button. The hob will enter operating mode.
- b) Press ON/OFF button during operation. The hob will stop operation. Child Lock will be activated automatically after 1 minute.
- c) While the hob is operating, press Child Lock button and then press ON/OFF button. If the hob is locked, "- -" symbol will be displayed.

POWER/TEMPERATURE ADJUSTMENT

The induction hob offers 9 power levels: 1st level is the lowest and 9th is the highest. You can adjust power/temperature using "+" and "-" buttons. Each time you press these buttons, sound alarm ("beep") is generated.

TIMER

Timer settings range is from 0 to 99. While the hob is operating, press Timer button. "Beep" sound alarm will be generated, "00"

figures will be displayed. Press "+" or "-" buttons to adjust time. Time count will start 5 seconds after the time is set. Upon expiry of the set time the hob will generate a sound signal.

CHILD LOCK

While the4 hob is operating, press and hold for 3 seconds the Child Lock button to lock the controls. The hob will generate a sound signal and "LO" will be displayed on the display. While the Child Lock is ON, all other buttons except ON/OFF button and Lock button will be locked.

SMALL ITEM RECOGNITION

In the event that small-size items (such as a knife, fork, key, etc.) have been left on-top of the hob, the hob will generate an audio signal and pause operation. If after 1 minute the item will not be removed, the hob will turn off to avoid damage.

AUTOMATIC COOKWARE RECOGNITION

In the event that cookware has been removed from the burner during the hob operation, or if inappropriate cookware is used, the induction hob will generate an audio signal and pause operation. If after 30 seconds the cookware will not be put back onto the burner/replaced with the proper cookware, the hob will turn off to avoid damage.

VOLTAGE SURGE PROTECTION

In the event of voltage surge the hob will automatically switch off.

FAULTY TEMPERATURE SENSOR PROTECTION

In the event of temperature sensor failure the induction hob will switch off and resume operation only after the temperature sensor fault will have been fixed.

OVERHEATING PROTECTION

In the event that the temperature either inside or on the surface of the hob becomes excessively high, the hob will automatically switch off and resume operation only after the temperature will reduce to rated values.

OVERVOLTAGE PROTECTION

In the event that the mains voltage becomes too high or too low, the induction hob will switch off and resume operation on after the voltage will return to rated values.

AUTOMATIC SWITCH OFF

In the event that within 2 hours no actions have been performed with the hob , it will automatically switch off.

Installation and Operating Manual

SUITABLE COOKWARE

Induction cooking is based on the use of magnetism to generate heat. Therefore, the cookware must be made of materials containing iron. You can check the material of your cookware with a simple magnet.

Important (see Figure 4):

To avoid irreparable damage to the surface of the hob, do not use:

- cookware with uneven bottom;
- metal cookware with enameled bottom;
- cookware with rough, abrasive bottom to avoid scratching the surface of the hob.

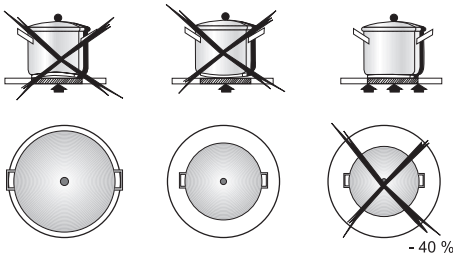

Fig. 4

MAINTENANCE AND CLEANING

The ceramic hob remains clean for a long time, it is simple to take care of, provided it is maintained in right manner and on a regular basis.

Clean the hob after each cooking, when the hob will have cooled down to normal temperature (when you will be able to touch it without hurting yourself). Otherwise, even the smallest remains of food will be burnt after the hob is switched on next time.

We recommend that you use only special non-abrasive cleaning agents to clean the glass-ceramics surface of your hob.

Never clean the glass-ceramic hob with steel brushes, coarse sponges or powder cleaners, as they scratch the surface of the hob. Sprays for grills and ovens also should not be used, because due to their high aggressiveness they can damage the hob (see Figure 5). Avoid the use of chemically active cleaning agents, such as, for example, stain remover.

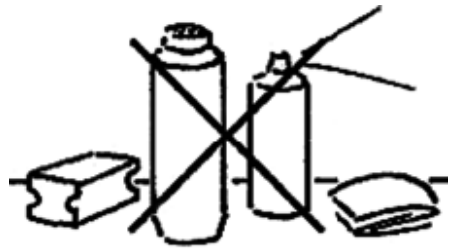

Fig. 5

Installation and Operating Manual

SLIGHT CONTAMINATIONS

Small stains and slight dirt should be removed with a damp cloth with a small amount of detergent for manual dishwashing, or a bleach for laundry. The remaining detergent should be washed off with cold water, and then the surface must be wiped dry.

Stains left by boiled out water should be removed with vinegar, or lemon juice, or with solutions intended for the dissolution of lime. If any of these chemicals has accidentally fallen on the metal frame (if any, depending on the model), it should be immediately removed with a damp cloth, otherwise matte spots will be left on the frame.

SEVERE CONTAMINATIONS

Cleaning agents should be applied neat using paper towel and then rubbed into the surface. Leave the cleaning agent for a while, so that it react with the dirt, then wash it out with cold water and wipe dry the surface of the hob. If the cleaner was not wiped out from the hob completely, it may damage the surface when it is heated up.

Extremely severe, heavy contaminations should be removed with a glass cleaning scrapper (see Figure 6). These scrapers are commercially available in the market. When purchasing the scrapper, pay attention to its handle. The handle must not be made of plastic, since the plastic can melt when the scrapper is used for cleaning hot surface.

Even if the hob color has changed, it doesn't affect its functionality and service life. This discoloration doesn't affect the structure of the hob material, being just a residues of the burnt out foods, which haven't been cleaned or removed in time.

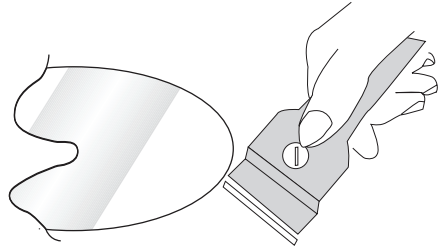

Fig. 6

Discoloration coupled with metal shimmering is caused by the friction between cookware bottoms and glass-ceramic hob, or the use of inappropriate cleaning tools. This discoloration still can be removed by using proper cleaners, although it will take lots of efforts and time. Cleaning can be repeated several times, until a contamination is completely removed.

In the event that lemon juice or vinegar, or lime scale removal agents get in contact with the metal frame around the glass-ceramic surface, this may result in damaging of the frame, as well as to the creation of discolored or other stains on the surface.

INSTALLING THE GLASS-CERAMIC HOB

WARNING!

The hob must be installed by qualified personnel only.

The hob must be installed in proper manner in strict conformity with the regulations of local electricity supplier and applicable standards.

During the entire process of installation the hob must be disconnected from mains. The hob must be installed so as to ensure protection against accidental contact with the details under voltage.

The surface used for building in the hob, must withstand 100°C.

In the event that a built-in oven or any other appliance, which becomes hot during operation, are installed beneath the hob and its control panel, it is required to ensure, that the temperature in close proximity to the control panel of the hob will not exceed 60°C. Failure to comply with the requirement may result in improper operation if the sensor control panel. To this end it is required to provide 40 mm gap between this appliance and the bottom of the hob (see Figure 8). Failure to comply with this requirement may adversely affect operation of the control panel.

The gap between the bottom of the hob and the shelf of the kitchen furniture, which is the closest to the hob, must be at least 25 mm.

FASTENING TO THE COUNTERTOP

Cut out an opening with the dimensions, as shown in Table below, in the countertop, into which you are going to install the hob.

The countertop material tends to get wet relatively fast. Therefore the edges of the opening cut out in the countertop must be protected with special glue or sealant to protect it against the effects of condensed vapor, which may appear on the reverse side of the countertop.

Before proceeding with the installation of the hob into the opening in the countertop (see Figure 7), attach the adhesive sealing tape **G** to the bottom edge of the hob. Attach the sealant evenly along the entire perimeter of the hob. Avoid gaps and overlaps.

Now install the hob into the opening in the countertop. Align it right in the center of the opening. In so doing, hold the hob by its bottom part. Then press the hob against the countertop, so that the hob is steadily supported by the countertop. It is recommended to perform this operation with an assistant to avoid displacements of the sealing tape **G**.

If the sealing tape **G** is installed in correct and proper manner, it will provide reliable protection against spills of liquids. This is especially relevant from the standpoint of maintaining and cleaning the hob.

Installation and Operating Manual

Larger scale diagram
is given on Page 21

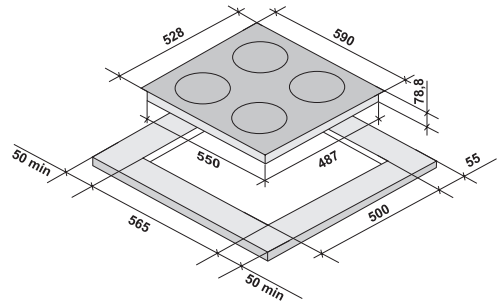

Fig. 7

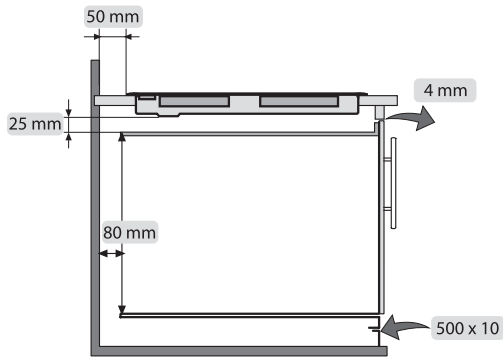
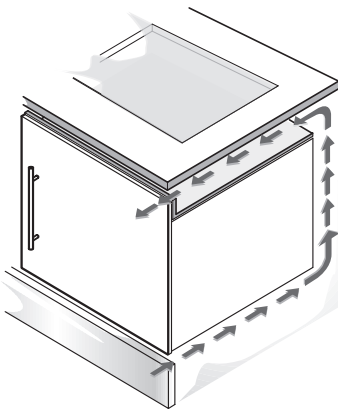

Fig. 8

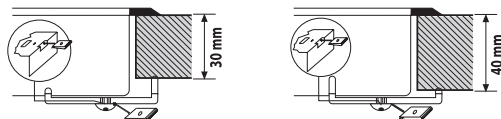
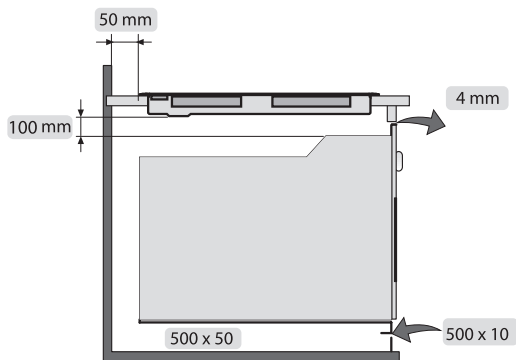
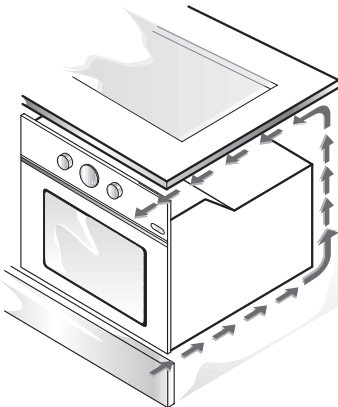

Fig. 9

Installation and Operating Manual

CONNECTION TO ELECTRIC MAINS

Before proceeding with connection of the hob to electric mains, please, make sure, that:

- specifications of the electric mains correspond to the figures specified on the nameplate of the hob, attached in the lower part of the hob;
- the electric mains is equipped with reliable and proper grounding system in conformity with applicable standards and regulations.

WARNING!

Since this device consumes significant power (7,2 kW), it MUST BE connected to a dedicated power supply line, having conductor cross-section of at least 4 mm².

The appliance must be connected to the electric mains in strict compliance with current standards and regulations.

Wiring diagram is given on Figure 10 below:

Fig. 10

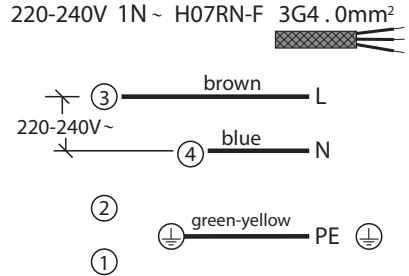
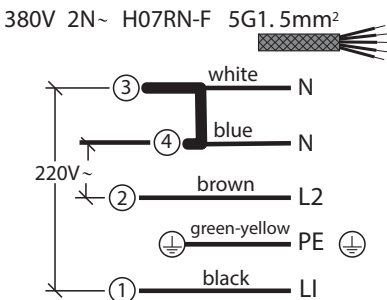

When the hob is connected directly to the mains, the connection must be made through the circuit breaker, which ensures at least 3 mm gap between open contacts.

This is not required in the event that the hob is connected to mains using wall outlet and plug, in which case these wall outlet and plug must be easily accessible in order to be quickly disengaged.

The plug and the cable used for connection of the hob, must meet all the applicable standards and be able to withstand the electric power consumed by the hob (see Max. Consumed Power, kW section).

Grounding wire (yellow-green) shall not be disconnected by the circuit breaker.

In any event power cord of the hob must be laid so that in none of its points the temperature would higher than the ambient temperature by more than 50 °C.

In the event that the power cord needs to be replaced, the replacement power cord must ensure safe operation of the hob in view of the given electric power consumption and operating temperature.

WARNING!

Never use household extension cords, since they may get overheated and flare up.

The hob must be grounded. Manufacturer disclaims any and all liability for any damage whatsoever, if this requirement is not met.

If the power cord is damaged, it must be replaced with the new one by qualified service center personnel.

Before switching on the hob for the first time make sure, that it is free from any and all foil, stickers or metal frames (if any).

WARNING!

Manufacturer disclaims any and all liability for any damage whatsoever, if the above and/or any other usual electrical safety rules and regulations are not observed.

MAINTENANCE AND REPAIRS

This appliance does not require any special technical maintenance in excess of normal cleaning.

Prior to the shipment from the manufacturer's plant, this appliance has been tested and accepted by qualified and experienced quality control personnel so as to ensure, that the appliance is in proper and good working condition. Any repairs, which may become necessary in the future, must be performed with the maximum care and diligence.

It is strongly recommended to contact the nearest FORNELLI service center or the shop where you bought the product.

If your product is still covered by the manufacturer's warranty, then while calling service center advise the following information: warranty certificate number, defect description, model and serial number specified on the nameplate attached to the lower part of your hob.

If your hob is not covered by the manufacturer's warranty anymore, then while calling service center notify them the model and describe the defect. This will be sufficient.

WARNING!

Never try to make any repairs of this hob by yourself. In the event you found any defects of the glass ceramic hob, disconnect it from power mains. Never allow random people, other than qualified service personnel, to repair your hob.

TROUBLESHOOTING

If you faced troubles when operating the hob, please, read the table below before proceeding with the actual repairs.

Fault	Recommendation
After the hob is switched on, "beep" sound is missing and the display is off.	Make sure, that: - power cord and its plug have no damages; - mains circuit breaker is in good and proper condition; - there is no power outage in your house.
"Beep Beep" sounds within 30 seconds, symbol "E1" is displayed	Make sure, that: - the you are using is suitable cookware; - the cookware is correctly aligned with respect to the induction burner;
The hob has suddenly switched off with "Beep Beep" sound, symbol "E2" is displayed	Make sure, that the hob is not overheated. If the fault is caused by overheating, switch off the hob, let it cool down and switch it on again. Fan sensor may be damages, If so, contact service center.
The hob suddenly switches off, heats up from time to time	Heating up from time to time may occur as part of the warming-up function, certain low-power operating modes, frying mode, some other modes. This is normal.
The hob has suddenly switched off with "Beep Beep" sound, symbol "E3" is displayed	Power surge: voltage increased above 275 V
The hob has suddenly switched off with "Beep Beep" sound, symbol "E4" is displayed	Power surge: voltage dropped below 100 V
The hob has suddenly switched off with "Beep Beep" sound, symbol "E5" is displayed	E5 error indicates glass surface temperature sensor defect, Please, contact service center.
The hob has suddenly switched off with "Beep Beep" sound, symbol "E6" is displayed	Wrong button has been pushed, liquid has boiled away/insufficient amount of liquid
The hob has suddenly switched off with "Beep Beep" sound, symbol "E0" is displayed	Internal component failure, Please, contact service center.

PIA 60 INDUZIONE Installation Diagram

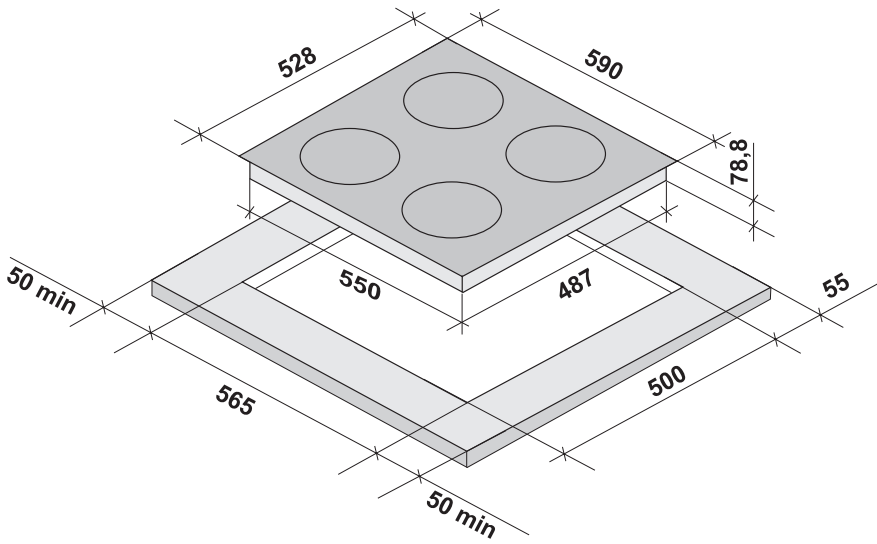

Warranty service conditions

The products are subject to free repair, if used only for personal, family or other needs, not related to business activities, or satisfying household requirements in an office of a company, institution or enterprise. The use of the products for purposes differing from above is deemed violation of the operation regulations.

The warranty certificate confers a right on free repair of the product within 12 months from the purchase date. Should you have any questions regarding the maintenance service, please contact the official representative of the brand. The contact details are on the web site of our partner krona-steel.com. Within the warranty period defective parts of the products are subject to free repair or replacement with new ones. It is the Service Center that has to decide whether the defective products shall be repaired or replaced.

The service life of the product is 7 (seven) years. The service life starts on the purchase date. If it turns out to be impossible to determine the purchase date, the service life shall start on the manufacturing date, encoded in the product serial number which is on the manufacturer's plate.

The manufacturer's plate availability is an obligatory condition! Make sure it is available and keep it for the entire service life of the product. If it is not available, it may turn out impossible to determine the product model, manufacturing date. As a consequence, a request for a free repair may be declined.

The free repair is only possible with a properly and duly filled in warranty certificate, sale receipt for a product purchased, other documents to confirm the warranty period of the product submitted for repairs or diagnostics.

When buying a product, make sure the warrant certificate is duly filled in, contains no corrections and bears the purchase date, the stamp of a sales

agency and signature of a sales assistant (including a tear-off card), model and the serial number of the product.

Before you call a Service Center specialist, please carefully read the operation regulations. If the product turns out to be non-defective upon diagnostics performed by the specialist, the Service Center reserves the right to demand an ungrounded call payment from the customer, basing upon the current price list.

For your safety, these are only licensed and authorized specialists and companies who are permitted to carry out installation and connection of gas operating equipment.

Please keep receipts and other documents with regard to installation and connection of your product for its entire service life.

Any complaints with regard to quality of the components are subject to consideration only upon the quality inspection (technical condition inspection) to be conducted by a representative of the authorized Service Center.

Kõik pretensioonid toote kvaliteedi ja detailide kompleksuse suhtes vaadatakse läbi pärast (tehnilise olukorra) kvaliteedikontrolli hoolduskeskuse autoriseeritud esindaja poolt.

The manufacturer shall not be liable for any damage to a customer or property of a customer and not be obliged to perform free repairs on the occurrence of any of the following:

- documents are missing to confirm the right for free repairs;
- repairs have not been performed by authorized persons, the product design has been changed, the product intervention is found, conflicting with the operation regulations;
- the operation regulations have been violated, stated in the product manual;

* Except backlight lamps, unless its replacement procedure is described in the operation manual. It is only the replacement procedure that is free, not the lamp itself.

Warranty service conditions

- installation regulations have been violated, as stated in the product manual;
 - the product has not been timely serviced and maintained, as the product manual requires;
 - the components and consumables have been replaced (accessories, lighting lamps*, filters, catalyst pads, plates, roasting jacks, grids, dishes and holders for microwave ovens, remote control devices, accumulators, batteries, etc., plastic parts handled manually;
 - consumables have been used, of improper quality;
 - defects and damages have been found caused by extreme conditions and force majeure circumstances (fire, Acts of God, etc.);
 - impact of water and solutions upon mechanical and electrical components of the product;
 - negligent storage and / or negligent transportation have been proved;
 - damages (failures) of the equipment, its malfunction due to animals or insects;
 - remains of food being cooked inside the product;
 - mechanical damage to the product (scratches, cracks, spalls, etc.);
 - loss of the saleable condition due to impact of chemicals;
 - use of cleaning / detergent agents, non-conforming to the type of the product;
 - thermal, mechanical and other damage of that kind that appeared while in operation;
 - the product uninstallation by a specialist of the Service Center turns out to be impossible (complex uninstallation procedures are subject to reassignment to the company that has installed the product);
 - unintended use of the product;
 - the warranty terms and conditions have been violated, as stated in the warranty document.
- The following is not subject to warranty services: adjustments, installation, cleaning and connection.

Fornelli

www.fornelli-tech.com